

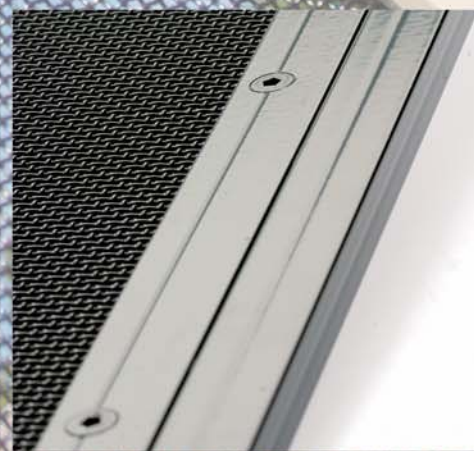

“Beat more burglars with the only security mesh that’s screw-clamped.™”



# Why Crimsafe beats more burglars -

## 1. We screw-clamp™ the mesh to give it enormous strength under attack

Only Crimsafe screw-clamps security mesh to the frame with tamper-resistant screws that go right through a metal clamp, through the mesh and into the frame. This gets repeated every 125mm around the frame.

The patented screw-clamp hooks into the aluminium frame and with its lever action creates a “single frame member” effect, meaning impacts are absorbed by spreading the load around the whole frame. And when screwed down, special teeth in the screw-clamp and frame “bite down” on the profile of the mesh to grip it tightly. (See diagram opposite)

The result gives Crimsafe its enormous strength against attack.

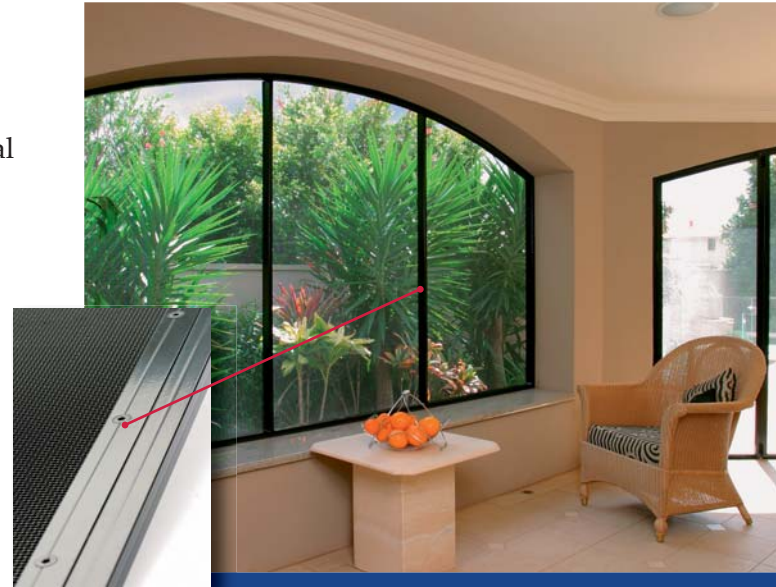

Crimsafe's tougher 'screw-clamp' design

## 2. Our 304 Security mesh is .9mm thick, so it's harder to break or cut

At .9mm in diameter, Crimsafe's Tensile Tuff® security mesh is extremely strong and hard to cut or penetrate. It also resists corrosion in coastal areas and harsh environments.

It carries a powerful Category 4 Cyclone ballistics rating (see our website for a full description of the test procedure) which proves its strength.

We developed Tensile Tuff specifically for use as a security screen product that would also be an effective insect screen and look great both from the inside and out. Made from 304 grade stainless steel wire, it has a special high tensile and elongation factor which gives it strength and the ability to be woven into a very tight, aesthetically pleasing mesh.

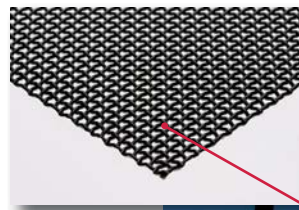

Thicker, stronger stainless steel mesh

## 3. Mid-rails come as a standard option to make our doors even stronger

Although all Crimsafe doors can be made without mid-rails - a mid-rail gives you these 5 great benefits:

1. It stiffens a door or enclosure, to resist attack.
2. It strengthens door locks against jemmy attacks.
3. It protects the hinges on a door by reducing a criminal's ability to lever the door from the wall.
4. It acts as a visual warning to prevent you from walking through an apparently open space.
5. It can become an architectural feature and give your doors more flexibility in design.



Mid-rails for extra strength, security and safety

# Crimsafe security up close -

- 1** The patented screw-clamp™ and hook feature transfers the force of an impact around the frame, so the mesh remains intact and the unit is able to withstand enormous impacts. In fact, all our standard domestic products are rated to resist Category 3 cyclones.
- 2** Tamper-resistant stainless steel screws, exclusive to Crimsafe screens, are driven right through the clamp and mesh and into the frame on the other side, to give the screen amazing strength. Crimsafe is the only security screen to feature mesh screwed into place like this, giving it unrivalled resistance to attack.
- 3** Only Crimsafe features specially developed 0.9mm diameter Tensile Tuff® Security Mesh. Developed from Premium Grade 304 high tensile stainless steel, it is the strongest mesh of its type, and is designed specifically for security.
- 4** The Crimsafe clamp and frame have special teeth designed to match the profile of the mesh and “bite down” on it with a vice-like grip.
- 5** The Santoprene® rubber insulator is so revolutionary it has its own separate patent. It reduces water penetration and salt buildup in harsh environments and virtually eliminates galvanic corrosion of the different metals – meaning a very long life for your screens. Santoprene does not degrade after prolonged exposure to ultra violet light (sunlight).
- 6** A special powder coat finish developed in conjunction with Dulux makes Crimsafe mesh the only commercial grade UV fade-resistant security screen. The coating gives longer life and makes cleaning easier, especially using the Ha Ra electrostatic glove available through Crimsafe licensees.

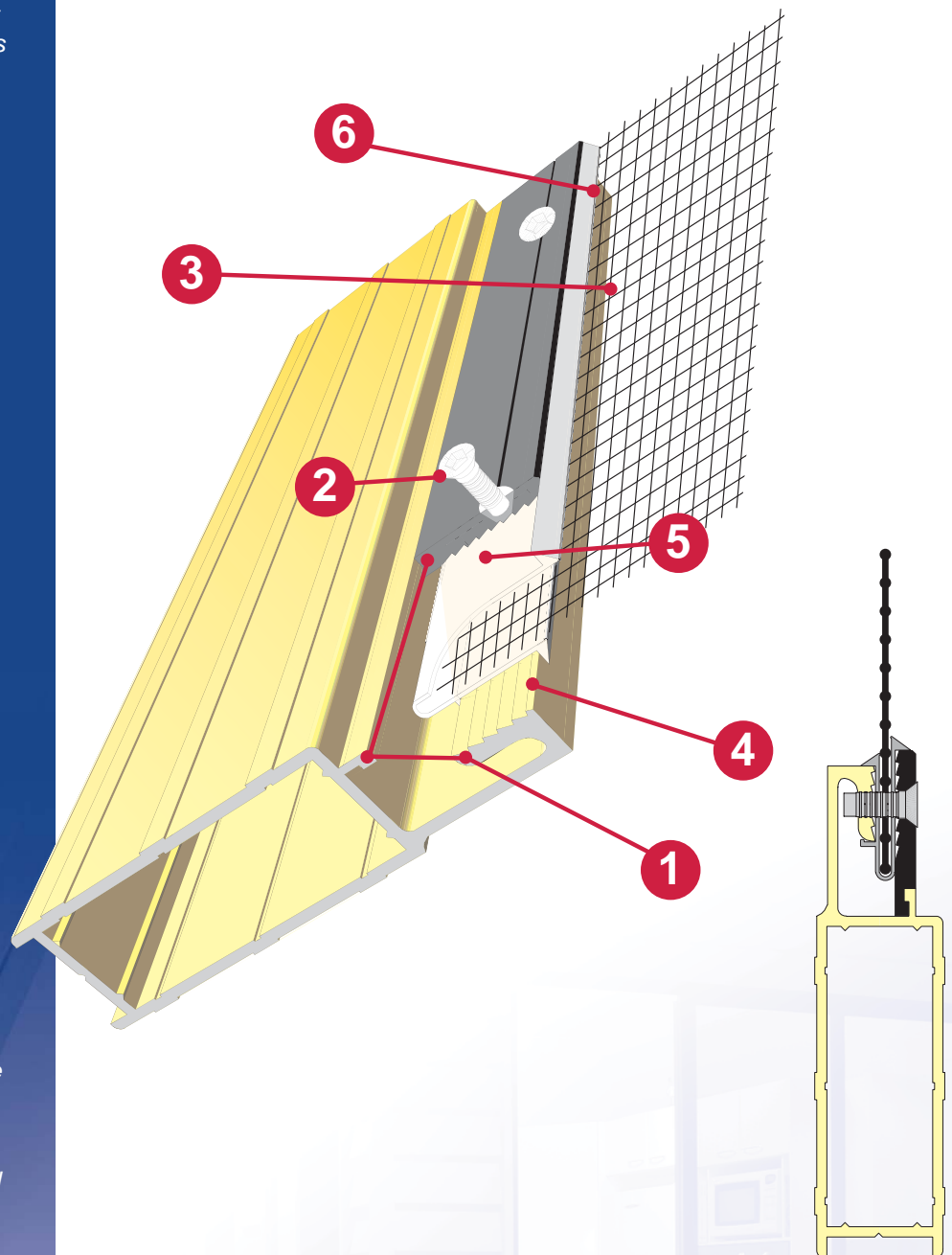

Crimsafe is proudly associated with:



## Real life testing -

We have tested Crimsafe using real life attack tests. Visit our website to see the real video of the tests – [www.crimsafe.com.au](http://www.crimsafe.com.au)

# We exceed Australian Standards -

Crimsafe has exceeded all the Australian Standards for security doors and windows, as well as some Industry Standards that are not compulsory but are testament to the product's great strength...

Australian Standard 5039 – 2003 specifies these tests:

- Dynamic Impact Test
- Jemmy Test
- Pull Test
- Knife Shear Test
- Shear Test
- Probe Test

Crimsafe has also passed these Industry Standards:

- Curtin University Category 3 Cyclone Missile Test
- BHP Category 4 Cyclone Missile Test (Commercial Grade Crimsafe Only)
- BHP Category 4 Cyclone Ballistics Test (Commercial Grade Crimsafe Only)

And Crimsafe scores highly on these "Rating Only" tests

- CSIRO Fire Attenuation Test
- Dulux and Chemetall 1000-hour Salt Spray Test

Find out more about the test results online at [www.crimsafe.com.au](http://www.crimsafe.com.au)

# Commercial Crimsafe for your business -

For our commercial systems, we:

1. Multiplied by 5 the number of tamper-resistant screws holding the clamp together – there's one every 25mm.
2. Drilled them in a staggered fashion to dramatically increase the strength and holding power of the system.
3. Doubled the clamp-to-mesh contact area for extra vice-like grip, and
4. Increased the thickness of the aluminium frame by more than 60% to repel any human attack.



# Secure doors, windows, patios... and lifestyle -



Secure, attractive sliding doors ...



... and windows



Patio enclosure

Crimsafe allows you to keep or enhance your lifestyle. Because you can leave regular doors and windows open, you can keep a cool house in summer and enjoy fresh air all year round without compromising your security.

Our doors and windows come in many different frame styles and a full range of standard colours, to match your home or business.

Visibility through Crimsafe mesh is unhindered. And Crimsafe is a flyscreen as well as a security screen.

We also have a range of products designed to let you escape quickly in an emergency. Called Safe-S-Capes™, they are a keyless exit system for windows. Although effortless to open from the inside, they feature Crimsafe's screw-clamp system plus a triple "anti-jemmy" system, which makes them just as hard to penetrate from the outside as all our other products.

Our patio enclosures allow you to secure an exterior area from burglars and mosquitoes. Crimsafe can even be made into balustrades and pool fences, using our specially designed rails and posts.

Safe-S-Cape® ... the secure, keyless exit system



Sliding screens



Hinged screens



Sliding doors



Hinged hhhdoors



Curved openings

# The Crimsafe 10 year general warranty -

Crimsafe warrants you, as the owner of a Crimsafe Security Product, that it is free from defects in materials supplied by Crimsafe under conditions of normal use for a period of ten years from the date of installation.

Please refer to our warranty care guide for more information. The Crimsafe Licensee that installs your Crimsafe Security Screens will provide you with a copy.



## There's a Crimsafe Licensee in your area -

We currently have more than 100 licensees right around Australia, in every major city.

### Crimsafe is in the details...

Your local Crimsafe Licensee has highly skilled salespeople and installers with extensive knowledge and experience in the security industry. They utilise the latest advances in security systems including patented, tamper-resistant screws. These can't be unscrewed with any ordinary driver tool. The driver tools they use are unique to Crimsafe Security Systems. Crimsafe keeps a register of who has each driver tool for your added security and protection.



Contact your local Licensee today

## Visit Crimsafe's Website

Crimsafe's website has dozens of photos to show how Crimsafe can secure your home or business and keep lifestyle and good looks. See our demonstration videos which show the strength of Crimsafe, and they will leave you in no doubt that you can put your faith in a product that really works.

Visit [www.crimsafe.com.au](http://www.crimsafe.com.au)